



Lochinvar®

HYDRONIC BUFFER TANK

Submittal Sheet

RBT-Sub-02

HYDRONIC BUFFER TANK

Job Name: _____ Model No. _____

Location: _____ Gal. Capacity: _____

Engineer: _____ Equipment Tag(s): _____

Agent/Wholesaler: _____

Contractor: _____

NOTES:

Standard Features

- › Glass-lined Steel Tank
- › High Density Foam Insulation
- › Drain Valve
- › Air Vent Connection
- › Bulbwell
- › 3-Year Tank Warranty

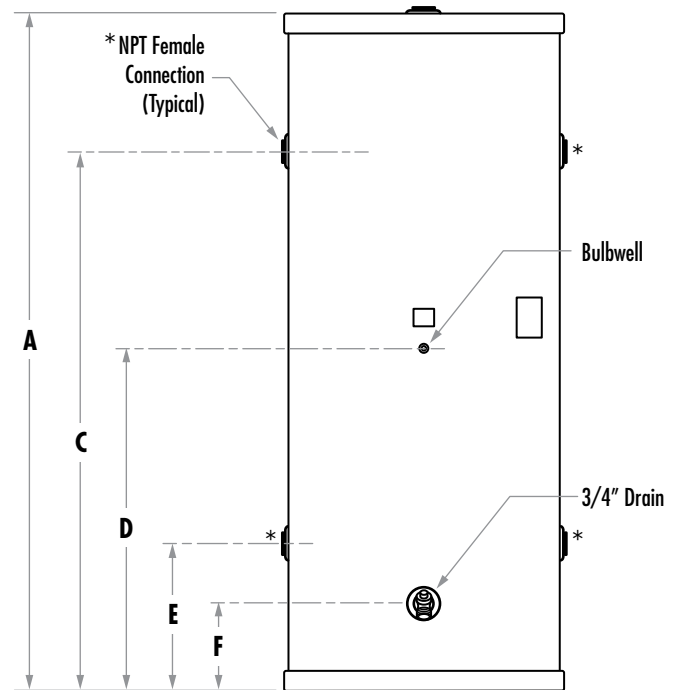
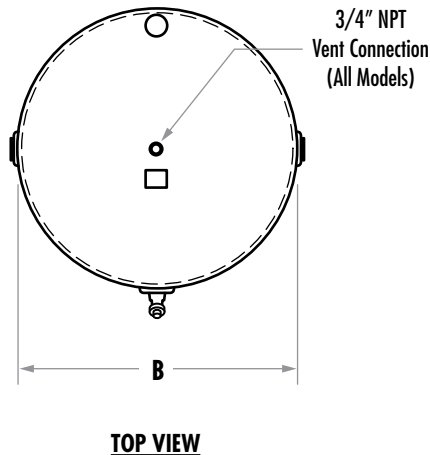

Model No.	Nom. Gal. Cap.	A	B	C	D	E	F	Supply/Return Connections	Ship Wgt. (lbs.)
RBT030	30	34-1/2"	20-1/2"	24-1/4"	17-1/8"	9-1/2"	4"	2" NPT	70
RBT050	50	53-7/8"	20-1/2"	41-5/8"	25-3/4"	9-1/2"	3-3/4"	2" NPT	120
RBT080	80	58-3/8"	24"	46-1/4"	29"	11-3/4"	3-3/4"	2-1/2" NPT	153
RBT119	119	61-5/8"	29-1/2"	48-1/2"	30-1/8"	11-3/4"	3-3/4"	2-1/2" NPT	198



Lochinvar®

Lochinvar, LLC
 300 Maddox Simpson Parkway
 Lebanon, Tennessee 37090
 P: 615.889.8900 / F: 615.547.1000

Lochinvar.com