

CONDENSING COMMERCIAL GAS WATER HEATERS



8 MODELS FROM 125,000 TO 500,000 BTU/HR

HIGH CONDENSING EFFICIENCY

5:1 TURNDOWN RATIO

DESIGN PREVENTS LIME SCALE BUILDUP

SMART CONTROL
OPERATING CONTROL WITH
LCD DISPLAY AND SOFT KEY BUTTONS



DESIGNED ★ ENGINEERED ★ ASSEMBLED

USA

 **Lochinvar**[®]



SHIELD – THE BETTER IDEA

The SHIELD™ commercial water heater features an advanced water heating system beautifully packaged for the smallest possible footprint. The SHIELD is available in eight models in standard and ASME construction. All utility connections are located at the top of the appliance to reduce equipment room footprint and increase installation flexibility. The Smart Control™ offers a bright, clear LCD display with soft-key buttons and a wide variety of advanced control functions. Additionally, a large removable pump access panel as well as the control can be found in the front of the cabinet making serviceability a snap.

LIME SCALE FREE FOR LIFE

The SHIELD water heater provides effective defense against a water heater's worst enemy – lime scale buildup on the tank and heating surfaces. Tank type water heaters suffer from one thing the SHIELD does not, lime scale buildup. Lime scale insulates the water from the heat source, decreasing thermal efficiency and increasing operating costs. Just a ¼" of lime scale will increase fuel consumption and raise operating costs as much as 25%. Shield has no flue tubes inside the tank. The water is heated in a separate stainless steel heat exchanger mounted above the tank. By controlling and creating high water velocity through the heat exchanger, the heat surface areas are kept clean so thermal efficiency remains high, for life.



"In-tank" flue tubes and heat exchangers suffer from lime scale buildup beginning from the first hours of operation.

FULLY MODULATING BURNER WITH 5:1 TURNDOWN

SHIELD can fire as low as 20% of maximum input when water heating demand is lowest, and increase to 100% for peak-demand periods. This results in better overall efficiency and less cycling compared to "on-off" tank-type units that can only fire at 100%.

'NEG/REG' SEALED COMBUSTION TECHNOLOGY

SHIELD utilizes an advanced combustion system which provides NOx ratings compatible with the most stringent air quality standards. Additionally, the NEG/REG sealed combustion technology allows the unit to operate with inlet gas pressure as low as 4 inches water column.

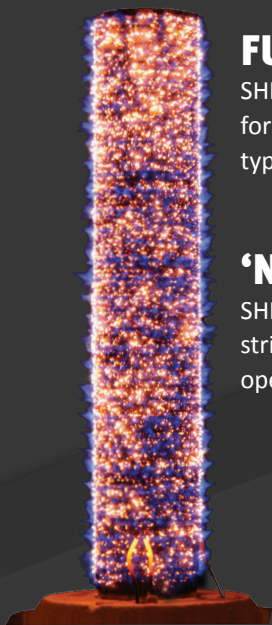

INSTALLATION FLEXIBILITY

As always, multiple SHIELD water heaters can be manifolded together to meet large demands. Now, with new optional side tapplings, a SHIELD can be connected to an additional heat source, such as an ARMOR water heater.



The SHIELD'S backlit display features the ultimate water heater control which makes system setup, service and operation a breeze. And now, the CON·X·US mobile communication platform allows SMART CONTROL to go where no other water heater has gone before.*

CON·X·US provides the ability to monitor and manage the SHIELD water heater without ever stepping into the mechanical room. CON·X·US will send alerts via text or e-mail with notification of changes in the system status. Once downloaded, the free CON·X·US mobile application allows for remote re-programming of key SHIELD functions using any internet-capable device.

* CON·X·US board sold separately. See back cover for a complete list of SMART CONTROL features.

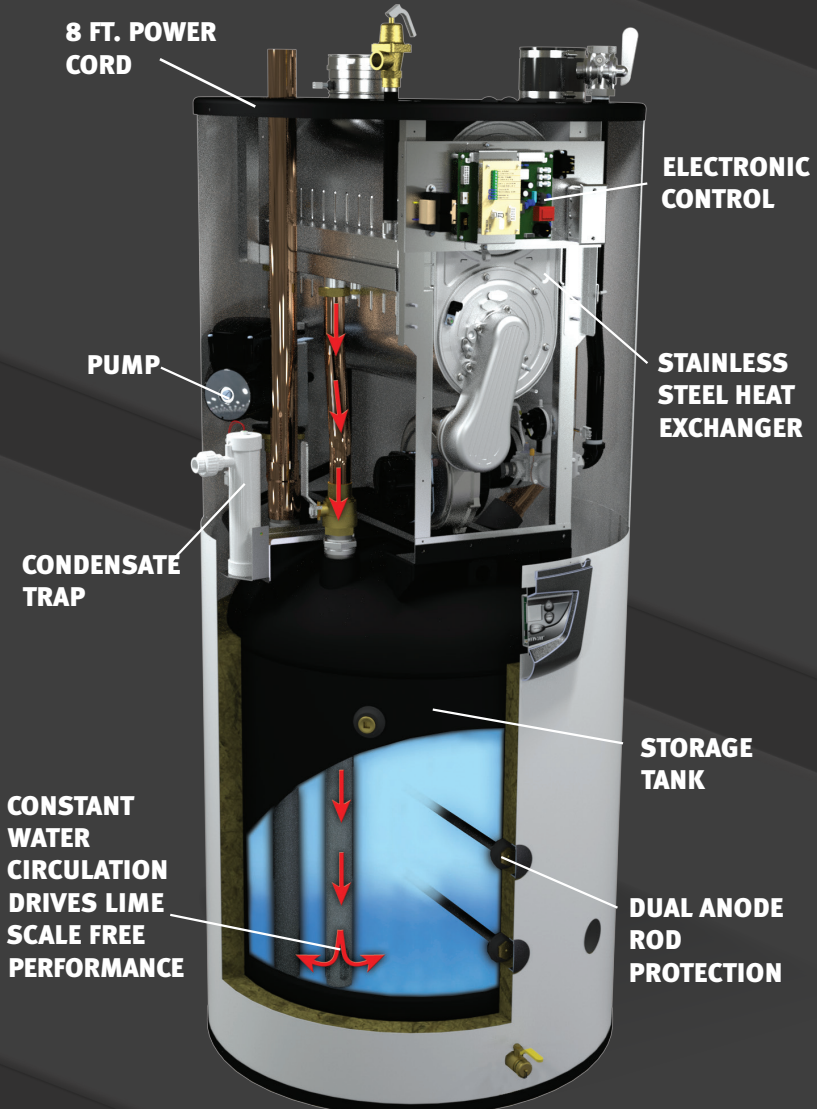

7 VENTING OPTIONS!

Room Air Vertical

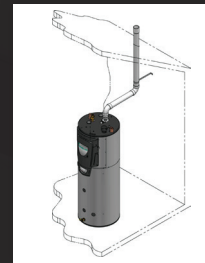

Room Air Sidewall



Direct Vent Vertical

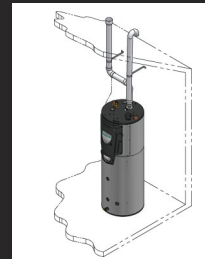

Vertical w/ Sidewall Air

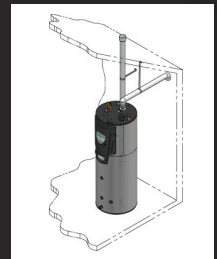

Direct Vent Vertical*

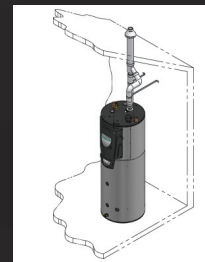

Direct Vent Sidewall*

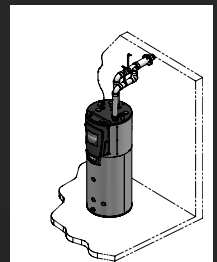

Direct Vent Sidewall

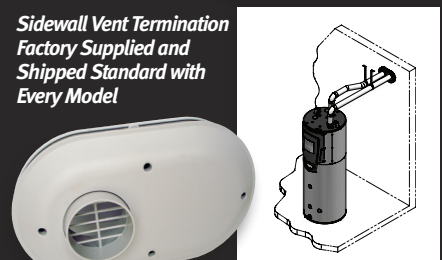

*Sidewall Vent Termination
 Factory Supplied and
 Shipped Standard with
 Every Model*



**Optional Concentric
 Vent Kit Sold Separately*

SHIELD™ WATER HEATER DIMENSIONS AND SPECIFICATIONS

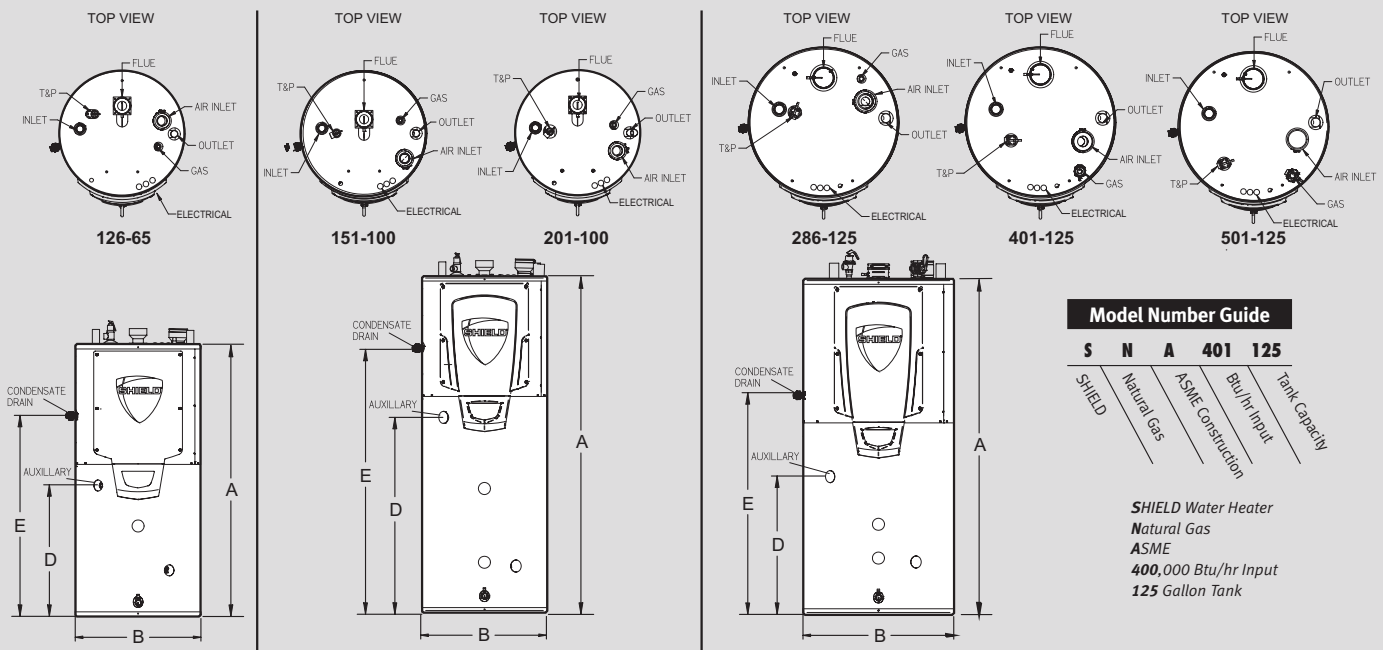

Model Number Guide

| | | | | |
|--------|-------------|-------------------|--------------|---------------|
| S | N | A | 401 | 125 |
| SHIELD | Natural Gas | ASME Construction | Btu/hr Input | Tank Capacity |

SHIELD Water Heater
 Natural Gas
 ASME
 400,000 Btu/hr Input
 125 Gallon Tank

| SHIELD™ WATER HEATER | | | | | DIMENSIONS AND SPECIFICATIONS | | | | | | | | | |
|----------------------|--------------|----------------|-----------------|----------|-------------------------------|-----|---------|---------|-----------|-------------|-----------|-----------|-----------------|--|
| Model Number | Btu/hr Input | Capacity (Gal) | GPH @ 100° Rise | 1st Hour | A | B | D | E | Gas Conn. | Water Conn. | Air Inlet | Vent Size | Ship Wt. (lbs.) | |
| SNR126-065 | 125,000 | 65 | 138 | 190 | 60-1/4" | 28" | 29-1/2" | 45-1/4" | 1/2" | 1-1/2" | 3" | 3" | 377 | |
| SNR151-100 | 150,000 | 90 | 165 | 237 | 75-1/2" | 28" | 44" | 59-1/2" | 1/2" | 1-1/2" | 3" | 3" | 700 | |
| SNR201-100 | 199,999 | 90 | 221 | 293 | 75-1/2" | 28" | 44" | 59-1/2" | 1/2" | 1-1/2" | 3" | 3" | 725 | |
| SNA151-100 | 150,000 | 90 | 165 | 237 | 75-1/2" | 28" | 44" | 59-1/2" | 1/2" | 1-1/2" | 3" | 3" | 700 | |
| SNA201-100 | 199,999 | 90 | 221 | 293 | 75-1/2" | 28" | 44" | 59-1/2" | 1/2" | 1-1/2" | 3" | 3" | 725 | |
| SNA286-125 | 285,000 | 120 | 314 | 410 | 75-1/2" | 34" | 31" | 49" | 3/4" | 2" | 4" | 4" | 800 | |
| SNA401-125 | 399,999 | 120 | 441 | 537 | 75-1/2" | 34" | 31" | 49" | 1" | 2" | 4" | 4" | 850 | |
| SNA501-125 | 500,000 | 120 | 552 | 648 | 75-1/2" | 34" | 31" | 49" | 1" | 2" | 4" | 4" | 875 | |

Change N to L for LP gas. Field convertible to LP Gas A = ASME Construction Electrical Requirements: 120V/1PH/60Hz All Information is subject to change.

STANDARD FEATURES

- Modulating Burner with 5:1 Turndown
- Operates at Temperatures up to 180°F for Sanitizing Applications
- Stainless Steel Heat Exchanger
- Glass-Lined Steel Tank
- Magnesium Anode Rods
- 150 PSI Working Pressure
- ASME Construction (SNA151-501)
- ASME Temperature and Pressure Relief Valve
- Zero Clearances to Combustible Material
- Certified for Installation on Combustible Floors
- PVC, CPVC, Polypropylene and Stainless Steel Venting up to 100 Equivalent Feet
- Direct-Vent Sealed Combustion
- Rooftop and Sidewall Venting
- Sidewall Vent Termination

Advanced SMART CONTROL

- LCD Display
- Time Clock
- Night Setback
- Alarm Contacts
- Runtime Contacts
- Manual Reset High Limit
- 3 Water Temperature Sensors
- Flue Temperature Sensor
- Contacts for Louvers
- Adjustable Pump Delay
- Security Protection
- Enable/Disable Contacts
- Low-NOx Operation, meets SCAQMD Rule 1146.2
- Low Gas Pressure Operation
- Direct-Spark Ignition
- Full Port Brass Drain Valve
- 8-Foot Power Cord
- 3-Year Limited Warranty
- 1-Year Parts Warranty

OPTIONAL EQUIPMENT

- CON-X-US® Remote Connectivity
- Alarm Bell
- Concentric Vent Kit
- Condensate Neutralization Kit
- Low Water Cutoff Kit
- Tank Side Tappings for Alternate Heat Source



Lochinvar, LLC
 300 Maddox Simpson Parkway
 Lebanon, Tennessee 37090
 P: 615.889.8900 / F: 615.547.1000
www.lochinvar.com

